

YAMUNA CEMENT PRODUCTS

Ground, 197/2, Chikhli Vandsa Road, Bharat Petroleum,
Chikhli, Rethvania, Navsari, Gujarat - 396560.

+91 99255 59727 | +91 77779 77858

info@yamunaprecast.com | yamunacement35@gmail.com
www.yamunaprecast.com



Scan For More Details



WHO WE ARE

At **Yamuna Cement Products**, we are committed to delivering high-quality cement and concrete solutions with reliability, durability, and precision. Established in **2016** in Chikhli, Navsari, we have grown into a trusted name in the industry, serving residential, commercial, and infrastructure projects across the region.

With a strong focus on quality manufacturing and customer satisfaction, we specialize in a wide range of products including **RCC Fencing Poles, Cement Poles, Fence Poles, Concrete Door Frames, and Concrete Cover Blocks**. Every product is manufactured using quality raw materials and modern production techniques to ensure long-lasting performance and strength.

Our dedicated team works with professionalism and efficiency to meet diverse customer requirements while maintaining consistent quality standards. Backed by years of industry experience, timely service, and a customer-first approach, Yamuna Cement Products continues to build lasting relationships based on trust and excellence.

We strive to deliver dependable products that contribute to

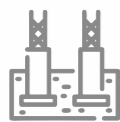

Stronger Foundation



Secure Boundaries



Durable Construction Solution



OUR CORE VALUES

At **Yamuna Cement Products**, our core values are rooted in quality, reliability, integrity, and customer satisfaction. We are committed to delivering durable construction solutions through modern manufacturing, timely service, and a dedicated team focused on trust, excellence, and long-term value.

OUR MISSION VISION

Our mission is to deliver high-quality, durable, and reliable cement and concrete products that meet the evolving needs of the construction industry, while ensuring customer satisfaction through excellence and timely service.

Our vision is to become a trusted leader in the industry by continuously improving our manufacturing standards, embracing innovation, and building long-term value through quality, trust, and sustainable growth.



DOOR FRAMES

Yamuna Cement Products offers high-quality RCC Door Frames designed for strength, durability, and long-lasting performance. Manufactured using premium-grade reinforced materials, they are resistant to termites, moisture, corrosion, and weather damage. Ideal for residential, commercial, and industrial projects, these door frames provide excellent stability, easy installation, and low maintenance.

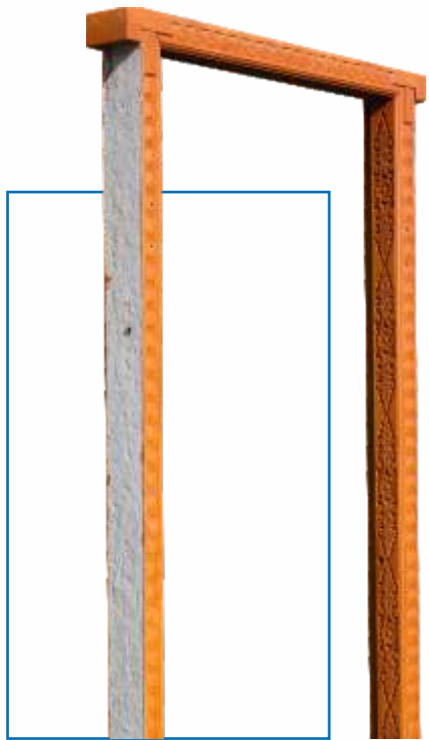

Door Frames
10 X 3 / 3 X 3.5 FT Flower Colour
5 X 2.5 / 2 X 2.5 FT Flower Plain
5 X 2.5 Flower Colour
5 X 2.5 Diamond Plain
5 X 2.5 Diamond Colour
5 X 2.5 Moulding Plain
5 X 2.5 Moulding Colour
5 X 3 Moulding Plain

Door Frames
5 X 3 Moulding Colour
5 X 2.5 Double Door Plain
5 X 2.5 Double Door Colour
4 X 2.5 Moulding Plain
4 X 2.5 Moulding Colour
4 X 2.5 Diamond Plain
4 X 2.5 Diamond Colour

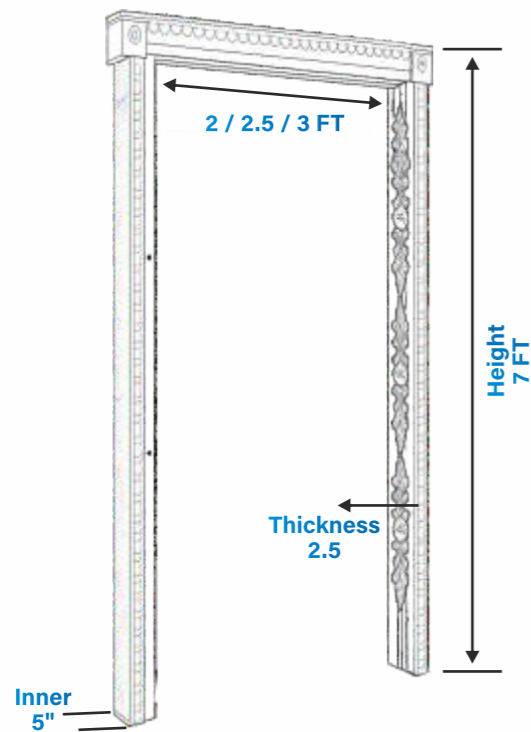

SS PIPE WINDOWS

Yamuna Cement Products offers premium-quality SS Pipe Windows designed for strength, durability, and modern aesthetics. Made from high-grade stainless steel, they provide excellent resistance to rust, corrosion, and weather conditions. Ideal for residential, commercial, and industrial applications, these windows ensure security, ventilation, and a sleek architectural finish with minimal maintenance.



SS Pipe Windows
4 X 3 Window Colour (Rubber Mould)
3 X 3 Window Colour (Rubber Mould)
3 X 2.5 Window Colour (Rubber Mould)
4 X 3 Window
3 X 3 Window
3 X 2.5 Window
3 X 2 Window
2 X 2.5 Window
1.5 X 2 Window

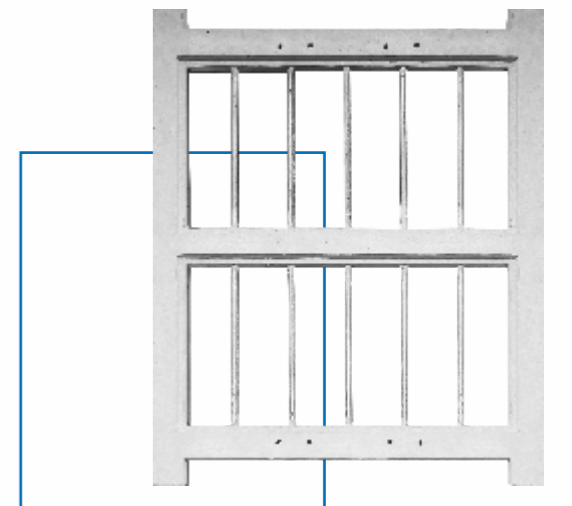



JALI RUBBER MOULD

Yamuna Cement Products offers high-quality Jali Rubber Moulds designed for durability, precise finishing, and repeated use. Made from premium-grade rubber, they ensure smooth texture, accurate designs, and easy demoulding for decorative cement jali applications with consistent and long lasting performance.

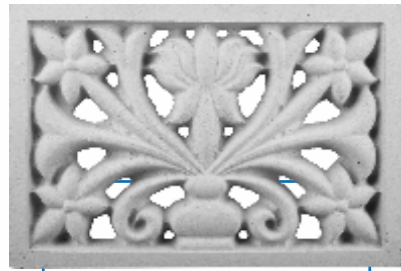

Y101 - Small Lotus

1 x 1.5 = 7.300kg
(Thick - 30mm)

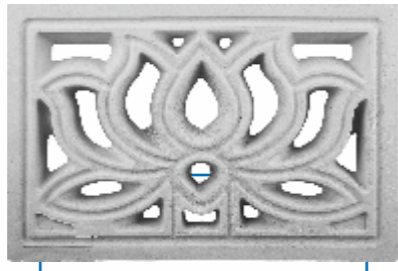

Y102 - Lotus

1.5 x 2 = 18.500kg
(Thick - 38mm)

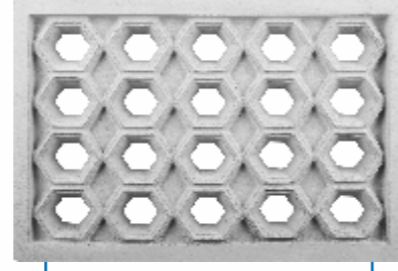

Y103 - Honey Comb

1 x 1.5 = 8.060kg
(Thick - 38mm)

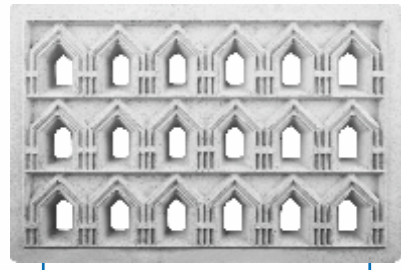

Y104 - Temple

1 x 1.5 = 8.540kg
(Thick - 32mm)

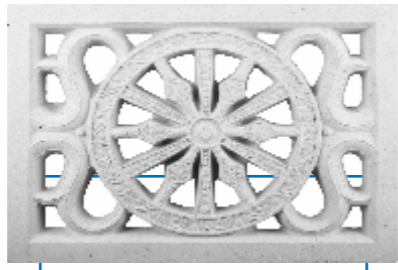

Y105 - Chakra

1.5 x 2 = 18.790kg
(Thick - 38mm)



Y106 - Chakra

2 x 1 = 10.3kg
(Thick - 45mm)

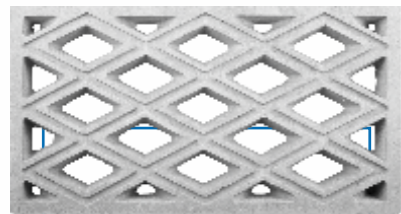

Y107 - Cross

2 x 1 = 10.500kg
(Thick - 32mm)

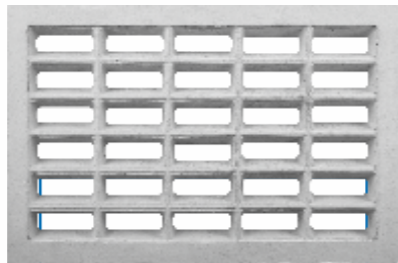

Y108 - Ventilation

1 x 1.5 = 6.350kg
(Thick - 32mm)

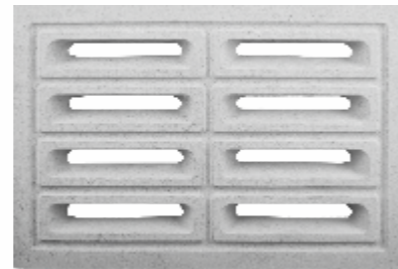

Y109 - Ventilation

1 x 1.5 = 7.600kg
(Thick - 32mm)

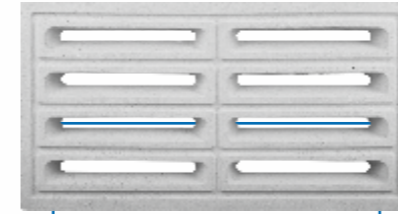

Y110 - Ventilation

2 x 1 = 10.640kg
(Thick - 32mm)

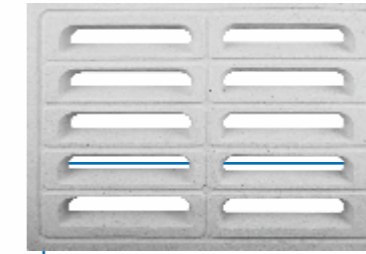

Y111 - Ventilation

1.5 x 2 = 17.630kg
(Thick - 38mm)

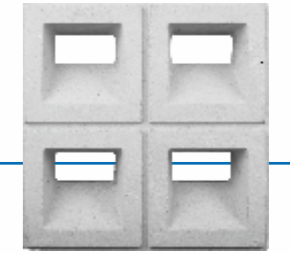

Y112 - Ventilation Heavy

300 x 300 = 11.60kg
(Thick - 70mm)

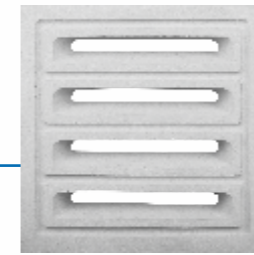

Y113 - Ventilation

1 x 1 = 5.100kg
(Thick - 32mm)

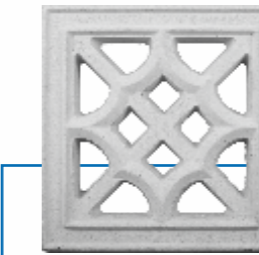

Y114 - Free Hand

1 x 1 = 4.600kg
(Thick - 32mm)

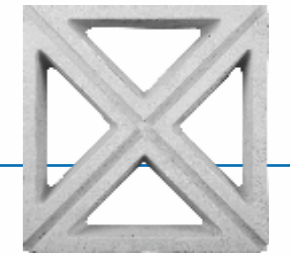

Y115 - Cross

1 x 1 = 5.820kg
(Thick - 50mm)

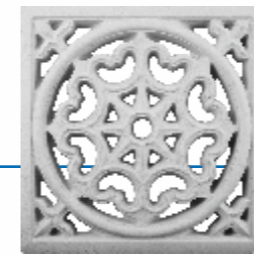

Y116 - Chakra

1.5 x 1.5 = 15kg
(Thick - 38mm)

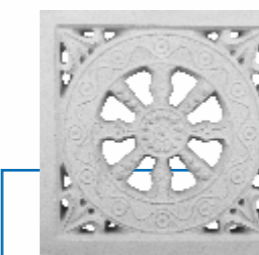

Y117 - Chakra

1 x 1 = 5.3kg
(Thick - 32mm)

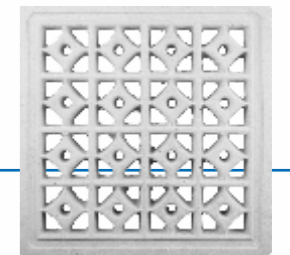

Y118 - American

2 x 2 = 25kg
(Thick - 45mm)



Y119 - Garden Jali

2 x 1 = 5.900kg
(Thick - 40mm)



Y120 - Garden Jali Mahakal

2 x 1 = 14.500kg
(Thick - 45mm)



Y121 - Garden Jali Hole

2 x 1 = 15.100kg
(Thick - 45mm)



COVER BLOCK

High-quality Cover Blocks designed for accurate reinforcement spacing and enhanced structural strength. Manufactured using premium-grade cement for excellent durability, load-bearing capacity, and long-lasting performance in slabs, beams, columns, and various construction applications.

Cover Block	
Wire	20mm, 25mm, 30mm, 40mm, 50mm, 75mm, 100mm
Heavy	50 x 60mm / 75mm

Cover Block	
Footing	50mm, 75mm, 20 x 25mm, 20 x 25 x 40 x 50mm
Pie	25mm, 30mm, 40mm, 50mm, 75mm

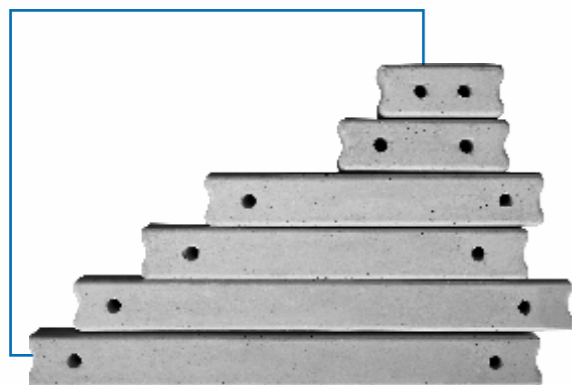
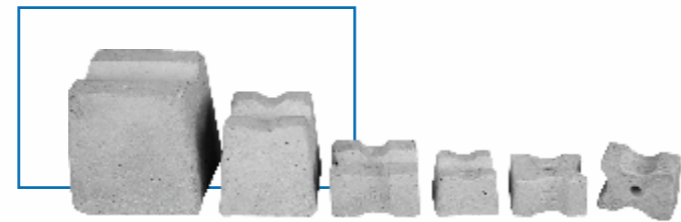
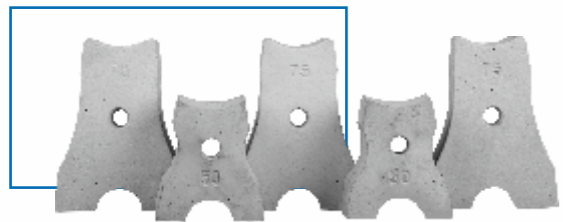
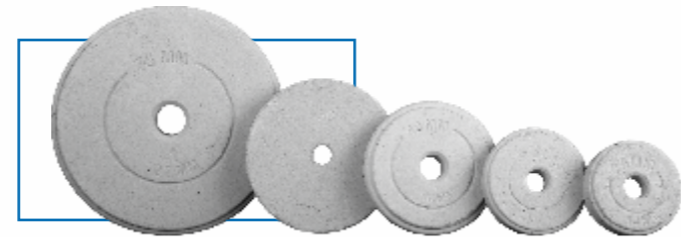
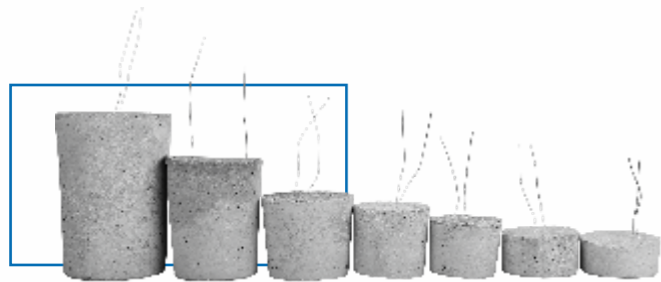

- 75mm
- 100mm
- 150mm
- 220mm
- 225mm
- 300mm

Distance Bar



U DRAIN WITH & WITHOUT COVERS

High-quality U Drains with and without Covers designed for efficient water drainage and long lasting durability. Manufactured using premium-grade cement for superior strength, smooth water flow, and excellent load-bearing performance in residential, commercial, and industrial drainage systems.

300 x 450 x 150 mm

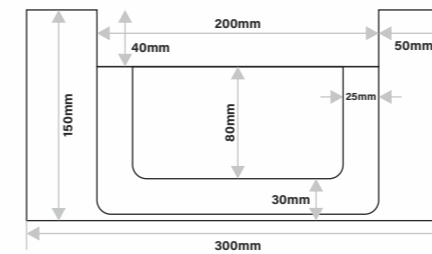
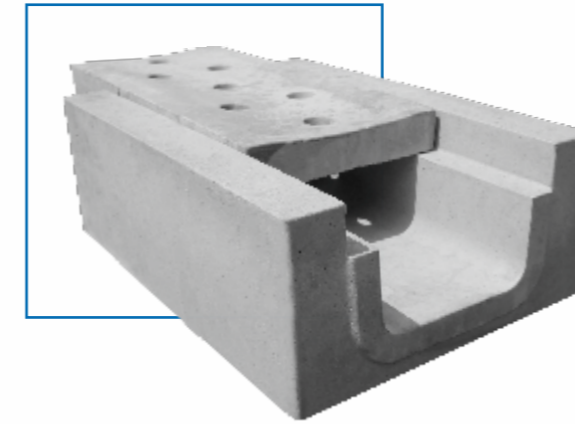

600 x 300 x 100 mm

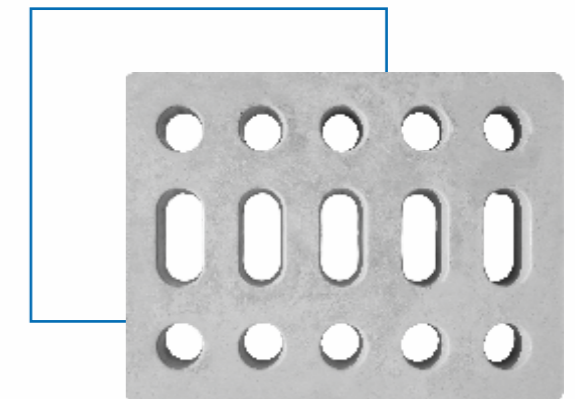
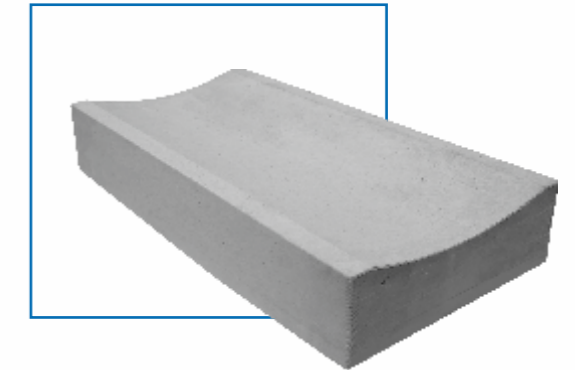

600 x 450 x 80 mm

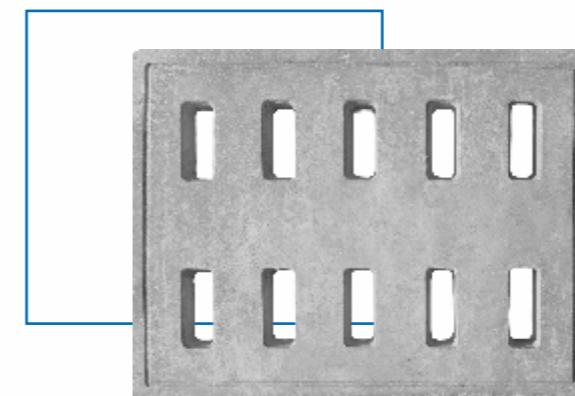

450 x 600 x 50 mm

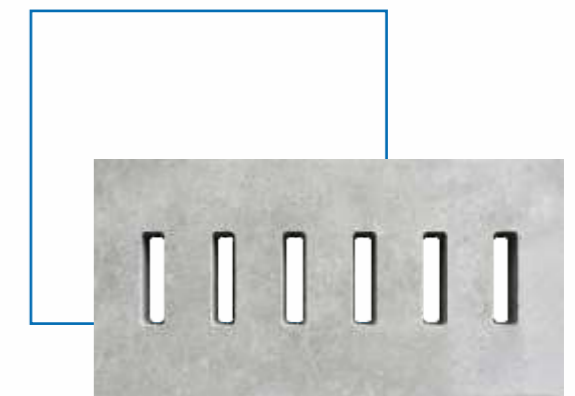

300 x 600 x 50 mm



MANHOLE COVERS

Durable and heavy-duty Manhole Covers designed for superior strength, safety, and long lasting performance. Manufactured using high-quality materials to withstand heavy loads, harsh weather conditions, and daily wear, making them ideal for residential, commercial, and industrial drainage applications.

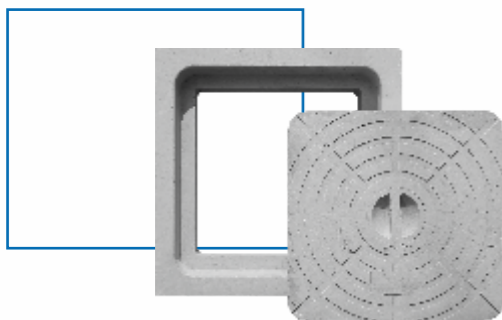
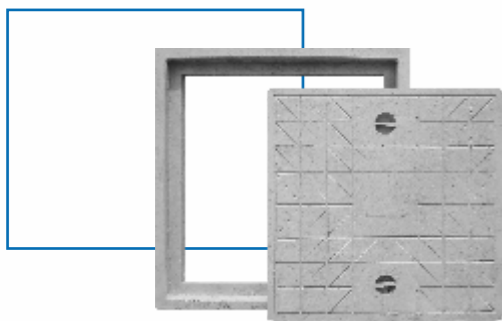
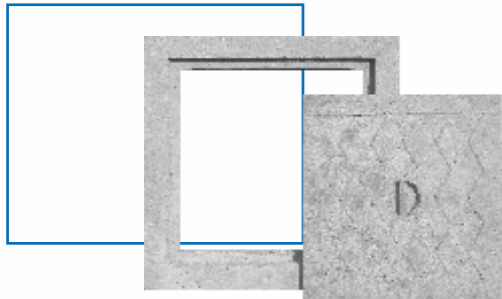
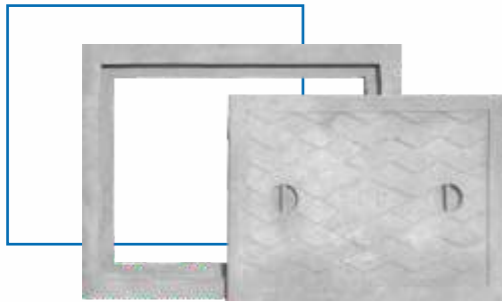

Manhole Covers	Weight
2 X 2 Regular	48kg
1.5 X 2 Regular	36kg
1.5 X 1.5 Regular	28kg
1.25 X 1.25 Regular	24kg
1 X 1.5 Regular	16kg
1 X 1 Regular	11kg
2 X 2 Ruber Mould	46kg
1 X 1 Ruber Mould	19kg
34 X 28 Heavy (35 TON)	220kg
28 X 28 Heavy (35 TON)	220kg
21 X 27 Heavy (35 TON)	130kg
24 X 24 Heavy (35 TON)	130kg
18 X 24 Heavy (35 TON)	100kg
21 X 21 Heavy (35 TON)	100kg
15 X 15 Heavy (35 TON)	70kg
24 X 24 (10 TON)	130kg
18 X 24 (10 TON)	100kg
21 X 21 (10 TON)	100kg
28 X 28 Round (35 TON)	200kg
25 X 25 Round (35 TON)	160kg
25 X 25 Round (20 TON)	120kg
36 X 36 (30 TON)	325kg



FRP MANHOLE COVERS

Durable and lightweight FRP Manhole Covers designed for strength, safety, and long-lasting performance. Manufactured using high-quality fiber-reinforced plastic, they offer excellent corrosion resistance, load-bearing capacity, and weather durability. Ideal for residential, commercial, and industrial applications with minimal maintenance requirements.

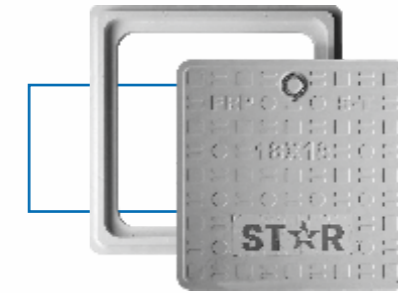
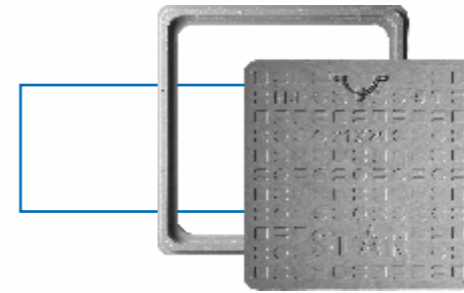

FRP Manhole Covers					
10 X 10 FRP	12 X 12 FRP	12 X 18 FRP	15 X 15 FRP	18 X 18 FRP	21 X 21 FRP
30 X 30 FRP	36 X 36 FRP	21 X 28 FRP	24 X 24 FRP	18 X 24 FRP	28 X 28 FRP

MARKING KHUTI

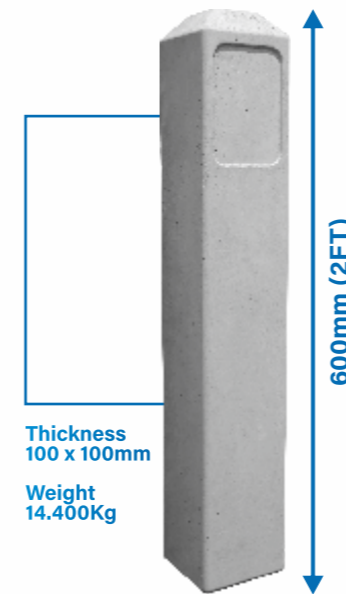

THAMBLI RUBBER MOULD

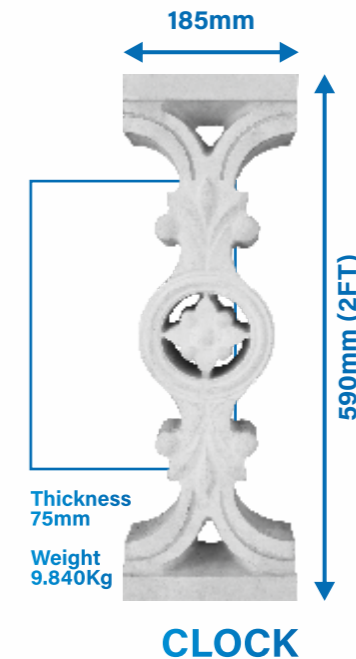



KERB STONES

Durable and precision-made Curb Stones designed for road edging, landscaping, and pavement protection. Manufactured using high-quality materials, they offer excellent strength, weather resistance, and long-lasting performance for pathways, gardens, parking areas, and roadside installations. Their sturdy construction enhances safety, durability, and visual appeal.

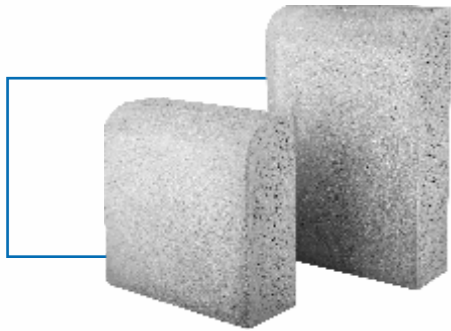

Curb Stone		
Width (mm)	Height (mm)	Thickness (mm)
300	300	100
300	450	100
600	300	100
600	375	150

Weight - 17.600Kg

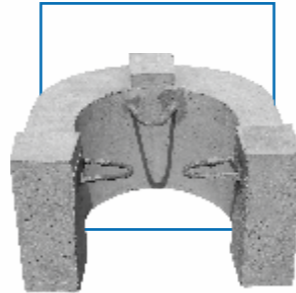

CHULA ROUND

Durable Round Chula designed for efficient heat distribution and long-lasting performance. Manufactured using high-quality materials, it offers excellent heat resistance, stability, and durability for traditional cooking applications. Its sturdy construction ensures low maintenance and reliable performance for residential and commercial use.

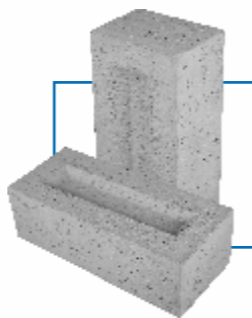

BRICKS

Width (inch)	Length (inch)	Thickness (inch)
4	9	3



Strong and durable Bricks designed for reliable construction and long-lasting performance. Manufactured using quality materials, they offer excellent strength, uniform shape, and superior load-bearing capacity for residential, commercial, and industrial projects. Their durability and weather resistance ensure strong foundations and lasting structural stability.



GRASS PAVER

Durable and eco-friendly Grass Pavers designed for ground stabilization, water drainage, and modern landscaping. Manufactured using high-quality materials, they offer excellent strength and load-bearing capacity for parking areas, pathways, gardens, and outdoor spaces. Their unique design supports natural grass growth while enhancing durability and aesthetic appeal.

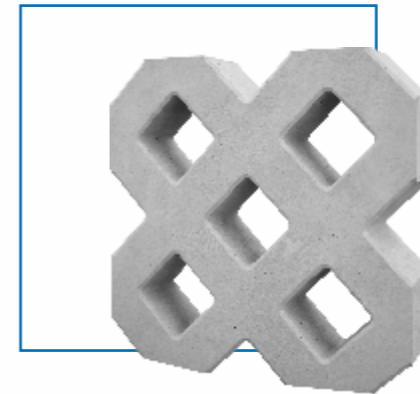

Grass Paver
250 X 250mm (10' X 10') 80mm
400 X 400mm (16' X 16') 80mm



TREE GUARD

815 x 815 mm
(Thickness - 80mm)

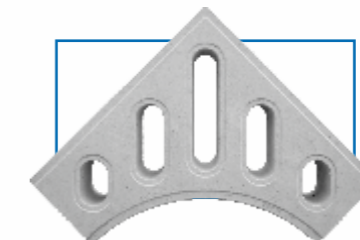

Durable and sturdy Tree Guards designed to protect plants and young trees while ensuring healthy growth. Manufactured using high-quality materials, they offer excellent strength, weather resistance, and long-lasting performance. Their robust construction provides reliable protection and enhances the appearance of outdoor spaces.



PAVER BLOCKS

High-quality Paver Blocks designed for strength, durability, and attractive outdoor flooring. Manufactured using premium-grade materials, they offer excellent load-bearing capacity, weather resistance, and long-lasting performance for pathways, driveways, parking areas, and gardens. Available in various designs to enhance functionality and aesthetic appeal.

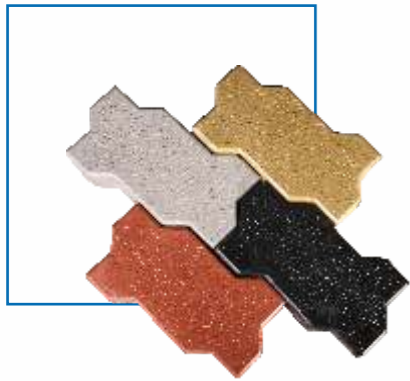

Paver Block
Zig-Zag (60mm)
Zig-Zag (80mm)
Zig-Zag (100mm)
8 X 8 (60mm)
8 X 8 (80mm)
8 X 4 (60mm)



SOLID BLOCKS

Width (mm)	Length (mm)	Thickness (mm)
180	390	140

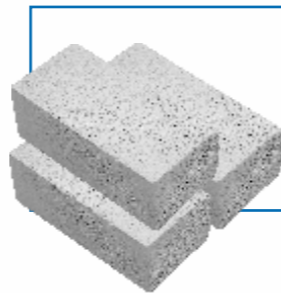

High-strength Solid Blocks designed for durable and reliable construction. Manufactured using premium-quality materials, they offer excellent load-bearing capacity, dimensional accuracy, and long-lasting performance for residential, commercial, and industrial projects. Their robust structure ensures superior stability, weather resistance, and quality construction.



TILES

Premium-quality Tiles designed to enhance durability, elegance, and modern architectural appeal. Manufactured using high-quality materials for superior strength, smooth finishing, and long-lasting performance, making them ideal for residential, commercial, and outdoor applications. Available in various designs, patterns, and finishes to complement stylish and functional spaces.

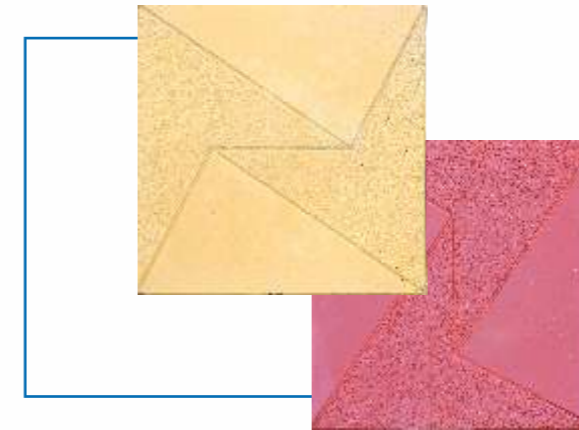

12 X 12

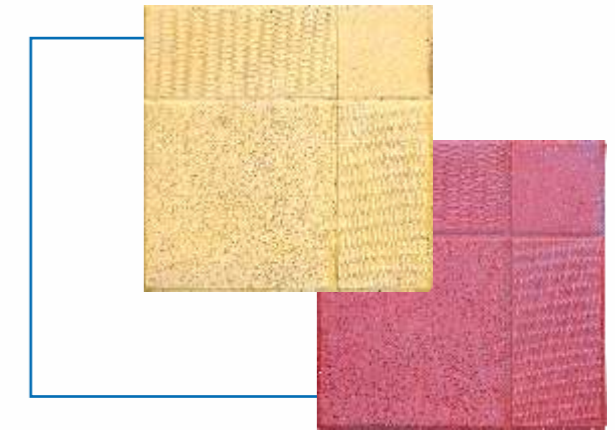

12 X 12

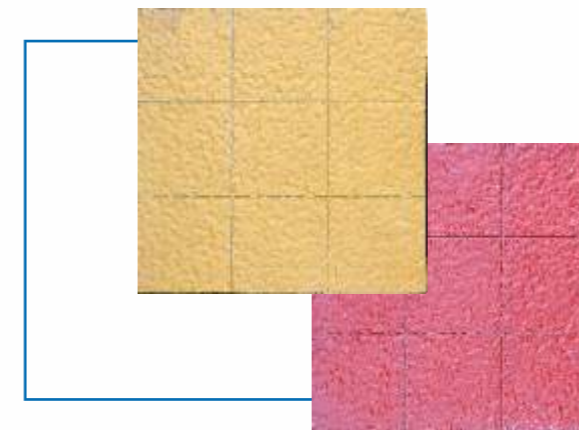

12 X 12

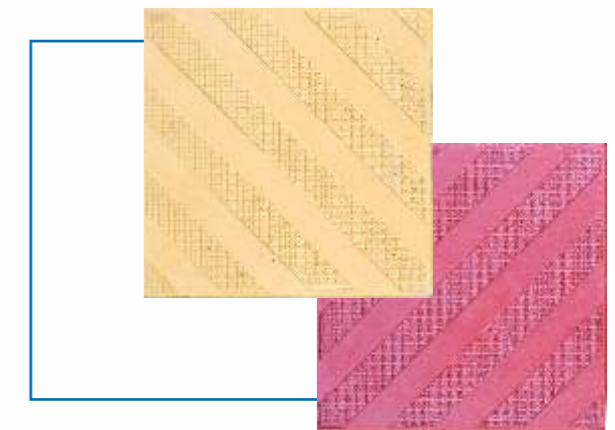

12 X 12

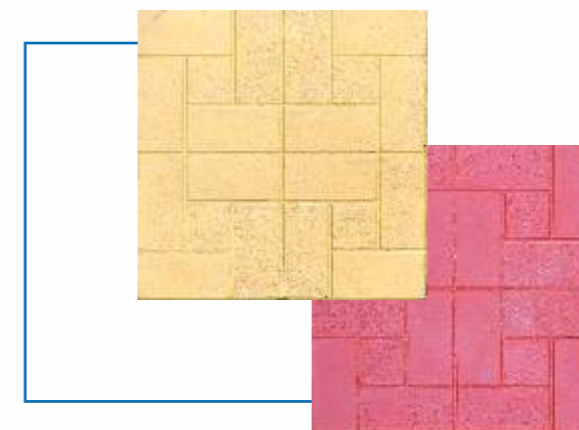

12 X 12



12 X 12